

PAPER NAME

**1. Determination Of Servant Leadership.
pdf**

AUTHOR

Trias Setyowati

WORD COUNT

4754 Words

CHARACTER COUNT

27419 Characters

PAGE COUNT

8 Pages

FILE SIZE

509.9KB

SUBMISSION DATE

Sep 19, 2024 11:20 AM GMT+7

REPORT DATE

Sep 19, 2024 11:20 AM GMT+7

● 17% Overall Similarity

The combined total of all matches, including overlapping sources, for each database.

- 17% Internet database
- 8% Publications database
- Crossref database
- Crossref Posted Content database

● Excluded from Similarity Report

- Submitted Works database
- Bibliographic material
- Quoted material
- Cited material
- Small Matches (Less than 8 words)
- Manually excluded sources
- Manually excluded text blocks

Determination Of Servant Leadership, Job Satisfaction And Work Environment Toward Job Performance Atuniversity Of Muhammadiyah Jember

Trias Setyowati¹, Diana Sulianti K Tobing²

¹(Departement Management, University of Muhammadiyah Jember, Indonesia)

²(Departement Management, University of Jember, Indonesia)

Corresponding Author : Trias Setyowati

ABSTRACT: This research had a purpose to analyze the influence of servant leadership, job satisfaction and working environment on the employees' performance at University of Muhammadiyah Jember. The type of research was a descriptive quantitative and the research design was explanatory. The population in this research was all University of Muhammadiyah Jember's employees. The samples used were 52 respondents, using the technique of probability sampling with simple random sampling approach. The analysis tool used multiple linear regression. The result showed that servant leadership, job satisfaction, and working environment partially or simultaneously had a significant effect on the employees' performance. Coefficient determination analysis showed that 86.3% of the employees' performance influenced by servant leadership, job satisfaction, and working environment. While the remaining 13.7% was influenced by other variables outside the model or equation, like motivation, allowances and others.

KEYWORDS: servant leadership, job satisfaction, working environment, employee performance

Date of Submission: 04-07-2018

Date of acceptance: 19-07-2018

I. INTRODUCTION

Employee performance is a very significant factor affecting the profitability of the organization (Bevan, 2012)[1], and inefficiencies in the performance of employees bring problems to the organization because they are associated with low productivity, profitability and decrease the effectiveness of the organization as a whole. As shown by Viswesvaran and Ones (2000)[2], employee's performance is the core of the construction of today's workplace. Employee's performance is defined as any behaviors or activities undertaken to achieve the goals and objectives of the organization (Motowidlo, Borman, & Smith, 1999)[3].

Performance is important for the organization as a result of the employee's performance and brings success and individual critical business performance as completing the task can be a source of satisfaction (Muchhal, 2014)[4]. The importance of Human Resources brings a consequence that every director is emphatically obliged to give attention to develop, mobilize, and direct all potential of the employees in order to realize the volume of their environment and workloads in reaching the goal. Leadership is a process of a person to move others; to lead, guide, and influence others to do something in order to achieve the expected results. These factors of leadership imply the central role of a leader to bring his organization to the objectives to be achieved, including how to manage stress of the employees working in the organization. (Sutrisno, 2009: 213)[5].

Servant Leadership was introduced by Robert Greenleaf in 1970 in his book, 'The Servant as Leader'. According to Greenleaf, a Servant Leadership is a leadership in which a leader performs as a servant. It starts with a natural sense that one serves others before he is served. Then, this sense brings a choice to someone to lead. The definition of servant leadership is an interrelationship process between a leader and his employees in which a leader initially performs as a servant that serves all his employees' needs, and at the end, he is recognized and accepted as a leader (Soundra, 2004)[6].

In addition to job satisfaction, comfortable working environment conditions also affect employees to work harder and to concentrate in completing the tasks on schedule. Agencies that have a good and comfortable working environment will motivate employees to improve their performance. Besides, good working conditions will reduce boredom and fatigue, which is expected to improve employees' performance. Working environment is a whole facilities and infrastructure that exist around employees who are doing the work (Rivai, 2006: 165)[7]. This will include the working environment, working facilities, cleanliness, lighting and tranquility. According Nitisemito (2008: 183)[8] working environment is everything that exists in the environment around the workers and that could affect them in carrying out the tasks assigned to them, such as hygiene, music, and other environments. From a physical and non physical understanding, it is true that working environment is an important factor in improving employees' morale and motivation in carrying out the work.

One of the things that must be considered in the implementation of the work in an organization that is the performance of its employees. The word '*kinerja*' is an abbreviation of kinetic performance energy that is equivalent as performance in the English language, and often referred to *performain* the Indonesian language (Rivai, 2006)[7]. To reach an optimal performance is not an easy task because the optimal performance can be achieved if the influencing factors can be applied properly and consistently in the organization. A leader should realize how he applies his leadership, how his company manages employees' stress and creates the best working environment for its employees to reach employees' optimal working performance.

The step of optimizing employees' performance within the organizations, including the University of Muhammadiyah Jember which is one of the private universities managed by Muhammadiyah Foundation is a very important factor. Low service quality reflects low employees' performance. Some employees at the University of Muhammadiyah Jember still show low working performance and indicate less effective and optimal in doing the tasks given. An example of this condition can be found at the Faculty of Economics, Management Department of University of Muhammadiyah Jember. The results of previous studies conducted by Syafitri, Riska (2014)[9] shows that the recapitulation of the questionnaire were not significant. It means that students' satisfaction does not relate to quick and accurate services of the employees. It also proves that the employees' performance is not maximum, and needs some changes to improve the employees' performance.

Employees' performance at the University of Muhammadiyah Jember is divided into several units consisting of the units of the Library, BAAK, Faculty Administration, where the average result of a questionnaire on students' ratings of the three services of the units was still quite good, but there were very few students that felt satisfied with the employees' service. The real conditions of the employees' performance at the University of Muhammadiyah Jember indicated that the employees have not fully shown optimal conditions, as presented in the following data:

Table 1.1 Total Students at University of Muhammadiyah Jember Year 2014-2017

Year	Target	Reality	Percentage (%)
2013/2014	2,200	2,390	108.7
2014/2015	2,000	2,076	103.8
2015/2016	2,000	2,019	100.95
2016/2017	2,000	1,934	76.7
amount	8,200	8,019	390.15

Source: UPT-PMB Universitas Muhammadiyah Jember

The study showed a phenomenon that the employees of University of Muhammadiyah Jember have not indicated an optimum services. It can be seen in Table 1.1 which indicates that the reality did not hit the target and the rate of decline in the year 2016-2017 reached 1,934 while the target was 2,000 students so that implied that the performance of employees decreased. Therefore, the researcher was interested in conducting an analysis of the influence of servant leadership, work satisfaction, and working environment on the employee's performance at the University of Muhammadiyah Jember.

II. LITERATURE REVIEW

2.1. Servant Leadership

Leadership problems have coincided from the beginning of human history. They have existed since human beings realized the importance of living in a group to achieve a common goal. It requires an individual or individuals that have higher competencies than others, regardless of any human group that is formed. It cannot be denied because humans always have certain strengths and weaknesses. Leadership is a field of researches that has been extensively studied over the past 30 years. However, the focus is on a servant leadership proposed by Robert Greenleaf in 1970, so it's not just a way of life management techniques but as a way of life that starts from a natural sense of someone to serve, giving service first (Parris & Peachey, 2013)[10].

According to Denniel & Lieven (2014)[11], Servant Leadership can be measured using an instrument that is called servant leadership Assessment Instrument (SLAI). Based on the instrument, the indicators of Servant Leadership are: 1) Love (affection). It is a leadership that emphasizes on love or affection. Love means to do the right thing on the right time to reach the best decision. 2) Empowerment. The emphasis is on the team work that means delegating power to others, and listening to employees' advices. 3) Vision. It is a futuristic vision of the organization that a leader brings. A vision inspires all actions and helps to form the future. 4) Humility. A Leader shows his humility by showing his respect to his employees and following the employees' contribution in a team. 5) Trust. Servant-Leaders are chosen people based on their certain strengths that lead to trust.

2.2 Job Satisfaction

The term work satisfaction reflects a person's attitude towards work and his organization and can be defined as the emotional reaction of employees to their work environment by evaluating actual results against those expectations (Philip & Gully, 2012)[12]. Saari and Judge,(2004)(13) found an evidence that job satisfaction is a predictor of employees' performance and has a very strong relationship for professional work. Effectively,employees' behaviour and job satisfaction affect their performance in effort of increasing their performance. (Philips & Gully, 2012)[12].

2.3 Working environment

Working environment according to Nitisemito (2002: 183)[8] is everything that is around the workers and that can affect them in carrying out the given tasks.A satisfactory working environment is able to improve workers' energy and enthusiasm to work in the company. Likewise, an unsatisfactory working environment decreases the workers' energy and enthusiasm to work that leads to low productivity.

Working environment is the whole facilities and infrastructures that exist around employees who are doing the work (Rivai, 2006: 165)[7]. It includes the working environment, working facilities, cleanliness, lighting and tranquility. According to Nitisemito (2008: 183)(8) working environment is everything that exists in the environment around the workers and affects them in carrying out the given tasks, such as hygiene, music, and others.

2.4 Employee performance

Employee performance is a stage in the decision-making process in which consumers actually buy. Decision-making is an activity of individuals who are directly involved in obtaining and consuming goods offered. Employee performance is an individual activity that is directly involved in decision making to purchase of products offered by the seller.Employee performance is a problem-solving approach on human activities to buy goods or service to meet their wants and needs consisting of an introduction to the needs and wishes, information search, evaluation of alternatives purchases, employee performance, and behavior after the purchase (Handoko, 2010: 162)[14].

Employee performance is the individual activities that are directly involved in the decision to make the purchase of the products offered by the seller. Hero (2009: 32)[15] explains that there are three activities that occurred in the process of employee performance by consumers, namely: (1) Consumers' routine in making a purchase, (2) The quality obtained from an employee's performance, (3) The commitment or loyalty not to change ordinary decisions that have been purchased to other competitors.

III. CONCEPTUAL FRAMEWORK FOR RESEARCH AND HYPHOTESE

29 Based on the literature review of some article then the conceptual conceptual model research can be presented as follow.

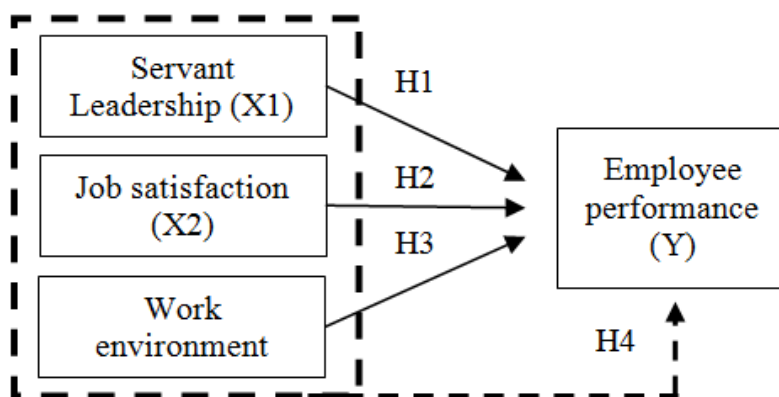

15 **Figure 2.1. Conceptual Framework**

Based on the conceptual framework model above the research can be submitted research hypohotesis as follow :

- H1: the better servant leadership the better the positive effect and significant effect on employee's performance on University of Muhammadiyah Jember
- H2: the better job satisfaction the better the positive effect and significant effect on employee's performance on University of Muhammadiyah Jember
- H3: the better working environment the better the positive effect and significant effect on employee's performance on University of Muhammadiyah Jember

H4: the better servant leadership, job satisfaction, and the working environment have a significant effect on employee's performance on University of Muhammadiyah Jember

IV. METHODOLOGY

4.1 Research Design

The type of research according to the level of the explanation was a descriptive quantitative. This research intended to explain the position of the variables that were analyzed and the relationship among the variables. On the other hand, a descriptive research is a research carried out to determine the value of an independent variable, either one or more variables (independent) without making comparisons, or relationships among variables. This research was a descriptive explanatory research. Sugiyono (2007)[16] states that, an explanatory research is a research that intends to explain the position of variables and the relationship between one variable and another variable.

4.2 Population and Sample

Population is a generalization region consisting of objects or subjects that have certain qualities and characteristics that set the researchers to learn and then drawn conclusions Sugiyono (2008: 115)[17]. The population of this research were 104 people taken from permanent employees of University of Muhammadiyah Jember.

Sample is part of the number and characteristics possessed by a population. The purpose is that the taken sample can provide enough information to estimate and draw conclusions relating to employee (Sugiyono, 2008: 116)[17]. The samples used in this study was 52 people that was 50% of the total population. The technique used in taking the samples was simple random sampling.

4.3 Data Collection Technique

Collecting data in this research used interviews, literature, documentation and questionnaire. The Questionnaire used was Likert scale. Likert scale is a series of statements formulated in accordance with the variables being studied.

4.4 Data analysis

The analytical tool used in this research is multiple linear regression. The equation used was based on the variables of this study:

$$Y = a + b_1x_1 + b_2x_2 + b_3x_3$$

The data analysis used research instrument tests (validity and reliability tests), a classic assumption test (a multicollinearity, hetero-scedasticity, and normality tests), hypotheses testing and coefficient of determination.

V. ANALYSIS

5.1 Result Research Instrument tests

1. Validity

Pearson's product moment correlation was used to measure the validity of the instruments of the research. It is done by correlating each statement with a total score, then the correlation results are compared with the number of critical significance at the level of 5%.

Table 4.1. Validity of Test Results

Statement	Sig (2-tailed)	α	Information
Servant Leadership			
x.1.1	0.000	< 0.05	invalid
x.1.2	0.000	< 0.05	invalid
x.1.3	0.000	< 0.05	invalid
x.1.4	0.000	< 0.05	invalid
x.1.5	0.000	< 0.05	invalid
Job satisfaction			
x.2.1	0.000	< 0.05	invalid
x.2.2	0.000	< 0.05	invalid
x.2.3	0.000	< 0.05	invalid
x.2.4	0.000	< 0.05	invalid
x.2.5	0.000	< 0.05	invalid
Work environment			

Statement	Sig (2-tailed)	α	Information
x.3.1	0.000	< 0.05	invalid
x.3.2	0.000	< 0.05	invalid
x.3.3	0.000	< 0.05	invalid
x.3.4	0.000	< 0.05	invalid
x.3.5	0.000	< 0.05	invalid
Employee performance			
2 y.1	0.000	< 0.05	invalid
y.2	0.000	< 0.05	invalid
y.3	0.000	< 0.05	invalid
y.4	0.000	< 0.05	invalid
y.5	0.000	< 0.05	invalid
y.6	0.000	< 0.05	invalid
y.7	0.000	< 0.05	invalid

3 Based on the validity of the test results known that all 2-tailed sig smaller than 0.05, so that the questionnaire used was valid.

8 **Reliability**

Reliability test is used to measure a questionnaire as an indicator or construct of a variable. A questionnaire is said reliable if one's answers of statements given are consistent or stable over time.

30 **Table 4.2. Reliability Test Results**

No.	Variables	Cronbach's Alpha	cutt off
1	Servant Leadership	0.718	> 0.6
2	Job satisfaction	0.687	> 0.6
3	Work environment	0.711	> 0.6
4	Employee performance	0.883	> 0.6

2 Reliability test results showed that all the variables have Cronbach's alpha values above 0.7, so the questionnaire was reliable.

Multiple Linear Regression Analysis

Multiple Linear Regression Analysis is one of analyses that aims to determine the effect of one variable against other variable. If there is only one independent variable and one dependent variable, the regression analysis is called as simple regression, whereas if there are more than one independent variables, then it is called a multiple regression equation (Priyatno, 2010)[18].

Table 4.3. Multiple Regression Analysis Results

No.	Variables	Coefficient
1	Constants	19.726
2	Servant Leadership	0.245
3	Job satisfaction	0.335
4	Working environment	0.583

10 Coefficient value of servant leadership variable was 0.245, indicating that if the value of servant leadership increased one unit then the performance of employees would increase 0.245 units, with an assumption that the variable of work satisfaction and working environment were constant or unchanged. The coefficient value also indicated that the servant leadership had a positive influence on the employees' performance. It means that the better the leadership, the better the performance of the employees of the University of Muhammadiyah Jember.

22 The coefficient value of working satisfaction variable was 0.335, indicating that if the value of job satisfaction variable increased one unit, then the value of employees' performance variable would reduce 0.335 units, with an assumption that the variable of servant leadership and the working environment were constant or unchanged. The coefficient value also indicated that job satisfaction had a positive influence on the employees' performance. It means that if the employees' satisfaction increased, then the performance of the employees of the University of Muhammadiyah Jember would increase, too.

3 The coefficient value of working environment variable was 0.583, indicating that if the value of the working environment variables increased one unit, then the performance of employees would increase by 0.583 units, with an assumption that the variable of servant leadership and job satisfaction were constant or

unchanged. The coefficient value also indicated that the working environment had a positive influence on employee performance. It means that the better the working environment, the better the performance of the employees of the University of MuhammadiyahJember.

Hypotheses testing

Table 4.4. Hypotheses Tests Results

variables	t test			F test		
	Sig.		α	Sig.		α
Servant leadership	0.033	<	0.05	0.000	<	0.05
job satisfaction	0.001	<	0.05			
Working environment	0.000	<	0.05			

Variable servant leadership had a significance value of 0.033 less than 0.05, so that the first hypothesis was accepted. It was proven that the servant leadership had a significant influence on the employees' performance. The result also indicated that the better servant leadership at University of MuhammadiyahJember, the higher (the better) the employees' performance.

Job satisfaction had a significance value of 0.001 and it was less than 0.05, so that the second hypothesis was accepted. It means that job satisfaction had a significant effect on the employees' performance. The result also indicated that the higher the employees' satisfaction, the higher (the better) the performance of the employees of the University of MuhammadiyahJember.

Working environment had a significant value of 0.000 and it is smaller than 0.05, so the third hypothesis was accepted. It means that working environment had a significant effect on employees' performance. The result also indicated that the better working environment of University of MuhammadiyahJember the better performance of employees would be.

F test result indicated the significance value was less than 0.05, then, the fourth hypothesis was accepted, it means that servant leadership, work satisfaction, and working environment simultaneously had significant effect on the employees' performance.

Determination Coefficient Analysis

The determination coefficient (R2) was used to measure the ability of the model to explain the dependent variable of the study.

Table 4.5. Result of Determination Coefficient

Criteria	Coefficient
Adjusted R Square	0.863

The result of determination coefficient analysis showed the adjusted R-square was 0.863, which means 86.3% of the employees' performance was influenced by servant leadership, job satisfaction and working environment. While the remaining 13.7% was influenced by other variables outside the model or equation, such as motivation, benefits and others.

5.3 Discussion

Based on the result of data analysis on the effect of servant leadership, job satisfaction and working environment on employee performance then can be describe some things as follows :

1. Servant leadership influenced the employees' performance

The test results proved that servant leadership had a positive and significant impact on the employees' performance. The results also suggested that if the better the servant leadership in the University of MuhammadiyahJember, the better the performance of the employees would be. Leaders have a duty and responsibility to pay serious attention to develop, mobilize, and direct all potential of his employees in order to create volume and workload focused on the goal. These results were consistent with the statement of Sutrisno (2009: 213)[5] who says leadership is a process of one's activities to mobilize, lead, guide, influence others to do something in order to achieve the expected results.

2. Job Satisfaction influenced on the employees' performance

The test results proved that job satisfaction had a positive and significant impact on the performance of the employees. The results also proved that job satisfaction was experienced by the University of MuhammadiyahJember employees. The higher the job satisfaction of the employees, the higher the level of decline of the employees' performance. Jobs often consume time and efforts beyond the desires of the individual

worker. Many workers do routine work, which is not or only slightly requires initiative and responsibility, with little hope of advancing or moving to other professions.

3. The influence of the working environment on the employees' performance

The test results proved that work environment had a positive and significant impact on the employees' performance. The results also proved that the better the environment the higher the employees' performance would be. Physical environmental conditions may include equipment, lighting, cleanliness and others. The unclean workspace will cause inconvenience for the employees to work. In addition, the lighting also gives considerable impact on the employees. Uncomfortable work place will indirectly affect the employees' performance to do the work. These results were consistent with Rivai(2006: 165)[7]who says working environment is a whole facilities and infrastructure that exist around the employees doing the work. According to Nitisemito (2008: 183)[8] working environment is everything that exists in the environment around the workers and that affectsthem in carrying out the assigned tasks, such as hygiene, music, and others. A more comfortable working environment also affectsthe employees to work harder and concentrate to complete tasks on schedule. Agencies that have a good working environment and comfortable will motivate its employees to improve their performance. Besides, good working conditions will reduce boredom and fatigue, which is expected to improve the employees' performance. These results were also consistent with the research done by Potu (2013)[19] and Jayaweera (2015)[20], which proved that the working environment had a significant influence on the employeea' performance.

VI. CONCLUSION

Based on the statistical testings, it can be concluded as follows:

1. Servant Leadership had a positive and significant impact on the employees' performance. The results also indicated that the better the leadership to serve in University of MuhammadiyahJember, th better performance of employees would be.
2. Job satisfaction had a negative and significant impact on the employees' performance. The results also indicated that the higher the employees' satisfaction, the better the employees' performance.
3. Working environment had a positive and significant impact on the employees' performance. The results also indicated that the better the working environment in the University of MuhammadiyahJember, the higher the employees' performance would be.
4. Servant Leadership, job satisfaction and working environment simultaneously had a significant effect on the employees' performance.

9 Suggestion

Based on the research results, the suggestions that can be given are as follows:

1. For the University of MuhammadiyahJember
 - a. The Executive Boardsof the University of MuhammadiyahJember should makea self evaluation, because there were some respondents who thought that the leadership at the University of MuhammadiyahJemberwas not quite good in their role. The evaluation can be done by means of a questionnaire survey sent to all employees at certain moments or each new academic year. The results of the survey, the Executive Boards will know directly how they performs their duty and responsibility in the eyes of the employees.
 - b. Universitas of Muhammadiyah
 - c. Jember should be able to strengthen the intimacy among the employees, as the results of the research showed that there were employees who felt they had co-workers who were bad in their relationship with others. To strengthen the relationship among the employees, the Boards can hold a recreation at certain moments for their employees, make an intense routine recitation activities and make a home visit to get closer friendship or through a small thingsuch as having lunch together, and others.
2. Further researchers

For further researchers are suggested to add the variables to enhance future researches. The variables of this research were Servant Leadership, job satisfaction and working environment. The three independent variables 86.3% influenced the employees' performance, and it means that there are other variables influence the employees' performance. The variables that need to be supplemented by subsequent researchers such as motivation, allowances, and others. So it will expand and enrich the research results in subsequent studies. Further researchers are also recommended to add the number of samples that will be used as the respondents. The more number of samples used the results will be more representative to potray the population.

REFERENCES

- [1]. Bevan, S. (2012), Good Work, High Performance and productivity. The Paper prepared for the european HRD Forume, Lisbon, 2012.
retrived From http://www.theworkfoundation.com/DownloadPublication/Report/316_Good%20Work%High%20Performance%20and%20Productivity.pdf
- [2]. Chockalingam Viswesvaran and Deniz S. Ones, (2000), Perspectives on Models of Job Performance, international journal of selection and assesment, Vol 8, No 4.
- [3]. Motowidlo, S.J. ; Borman, W.C. ; dan Schmit, M.J., (1997), "A Theory of Individual Differences in Task and Contextual Performance", *Human Performance*, 10 (2) : 71-83
- [4]. Muchhal, Devender Singh; Solkhe, Ajay, (2017), *An Empirical Investigation Of Relationship Between Emotional Intelligence And Job Performance In Indian Manufacturing Sector*, CLEAR International Journal of Research in Commerce & Management . Jul2017, Vol. 8 Issue 7, p18-21. 4p.
- [5]. Sutrisno, Edy. 2009. Human Resource Management. KencanaPemada Media Group, Jakarta.
- [6]. Reinke, Sandra J.(2004), *Service Before Self: Towards A Theory Of Servant-Leadership*,Global Virtue Ethics Review; Harrisburg, Vol. 5, Iss. 3,
- [7]. Rivai, Veithzal, 2006. The Company Manusiauntuk Resources Management: from theory to practice, First Edition, Publisher PT. King GrafndoPersada, Jakarta.
- [8]. Nitisemito S Alek, 2008. Personnel Management, Second Edition, Ghalia Indonesia.
- [9]. Syafitri, Riska. 2014. The Factors That Affect Student Satisfaction Management Department Of Economic Faculty Of University Of Muhammadiyah Jember. Essay. Jember: Universitas Muhammadiyah Jember.
- [10]. Parris, DL, & Peachey, J (2013). A. Systematic Literature review of servant leadership in organization theory context ., *Journal of Business Ethics*, 113 (3), 377-393.<http://doi.dx.org/10.1007/s10551-012-1322-6>
- [11]. McCann, Daniel & Cox Graves Lieven, 2014, Servant Leadership, Employee Satisfaction, and Organizational Performance in Rural Community Hospitals, *Journal International Journal of Business and Management*; Vol. 9, 10; 2014
- [12]. Phillips, JM, & Gully, SM (2012). *Organizational Behavior: Tool for success*. Mason, OH: South-Western
- [13]. Lise M. Saari and Timothy A. Judge, 2004, Employee Attitudes And Job Satisfaction, *Human Resources Mangement*, Vol 43, Issue 4, p 395 - 407
- [14]. Handoko, T. Hani (2010), *Manajemen, EdisiKedua*, Yogyakarta : BPFE.
- [15]. Hero. 2009. *Performance Evaluation of Human Resources: Theory and Research Applications*. Four Salemba, Jakarta.
- [16]. Sugiyono. 2007. *Education Research Methods Quantitative Approach, qualitative, and R & D*. Alfabeta, Bandung.
- [17]. Sugiyono. 2008. *Quantitative Research Methods, Qualitative and R & D*. Alfabeta, Bandung.
- [18]. Priyatno. 2010. *Statistical Analysis Data with SPSS*. Media Communications, Yogyakarta.
- [19]. Aurela Potu. 2013. *Leadership, Motivation and Work Environment Influence on Employee Performance at the Regional Office of Directorate General of State Triumph Sulutenggo and North Maluku, Manado*. Economics and Business Faculty. University of Sam Ratulangi, Manado.
- [20]. Jayaweera, Thushel, 2015 *Impact Factor of Work Environmental on Job Performance, mediating Role of Work Motivation: A Study of Hotel Sector in England*, the *International Journal of Business and Management*; Vol. 10, No. 3

Trias Setyowati "Determination Of Servant Leadership, Job Satisfaction And Work Environment Toward Job Performance Atuniversity Of Muhammadiyah Jember." *International Journal of Humanities and Social Science Invention (IJHSSI)* 7.07 (2018): 13-20.

● **17% Overall Similarity**

Top sources found in the following databases:

- 17% Internet database
- 8% Publications database
- Crossref database
- Crossref Posted Content database

TOP SOURCES

The sources with the highest number of matches within the submission. Overlapping sources will not be displayed.

1	europub.co.uk Internet	3%
2	pasca.unila.ac.id Internet	2%
3	ijstr.org Internet	1%
4	repository.unp.ac.id Internet	1%
5	researchgate.net Internet	1%
6	dspace.uui.ac.id Internet	<1%
7	noexperiencenecessarybook.com Internet	<1%
8	Hantono. "COVID 19: THE IMPACT OF DEMAND, SUPPLY, AND LABOR"... Crossref	<1%
9	journal.accountingpointofview.id Internet	<1%

10	Ade Gafar Abdullah, Isma Widiaty, Cep Ubad Abdullah. "Global Competi... Publication	<1%
11	jurnal.narotama.ac.id Internet	<1%
12	ijisrt.com Internet	<1%
13	ijhssi.org Internet	<1%
14	Hurriyati Ratih, Tjahjono Benny, GafarAbdullah Ade, Sulastri, Lisnawati.... Publication	<1%
15	ijble.com Internet	<1%
16	iosrjournals.org Internet	<1%
17	ijsshr.in Internet	<1%
18	Hera Oktadiana, Myrza Rahmanita, Rina Suprina, Pan Junyang. "Curren... Publication	<1%
19	eudl.eu Internet	<1%
20	garuda.kemdikbud.go.id Internet	<1%
21	ejournal.seaninstitute.or.id Internet	<1%

22	icmbt.uet.edu.pk Internet	<1%
23	ijrrjournal.com Internet	<1%
24	datasheet.hk Internet	<1%
25	scirp.org Internet	<1%
26	"Servant Leadership", Springer Science and Business Media LLC, 2010 Crossref	<1%
27	economics.academicjournal.io Internet	<1%
28	ijrcs.org Internet	<1%
29	webology.org Internet	<1%
30	journal.al-matani.com Internet	<1%

● Excluded from Similarity Report

- Submitted Works database
- Quoted material
- Small Matches (Less than 8 words)
- Manually excluded text blocks
- Bibliographic material
- Cited material
- Manually excluded sources

EXCLUDED SOURCES

ijhssi.org

Internet

67%

EXCLUDED TEXT BLOCKS

ABSTRACT: This research had a purpose to analyze the influence of servant leader...

www.europub.co.uk

environment is everything that exists inthe environment around the workers and

ijjsrt.com

individual activities that are directly involved in the decision to make thepurchase ...

repository.stie-aub.ac.id

is a stage in the decision-making process in which consumers actually buy.Decisio...

download.atlantis-press.com

is an individual activity that is directly involved in

economics.academicjournal.io

in carrying out the

ijjsrt.com

Saari and Judge,(2004

www.researchgate.net

Multiple Linear Regression AnalysisMultiple Linear Regression Analysis is

Siska Noviaristanti. "Contemporary Research on Business and Management", CRC Press, 2020